

546872 - Roanne Monobloc Sink Mixer Chrome

Useful Information	
Minimum operating pressure	0.3 bar
Maximum operating pressure	5 bar
Guarantee length	5 years

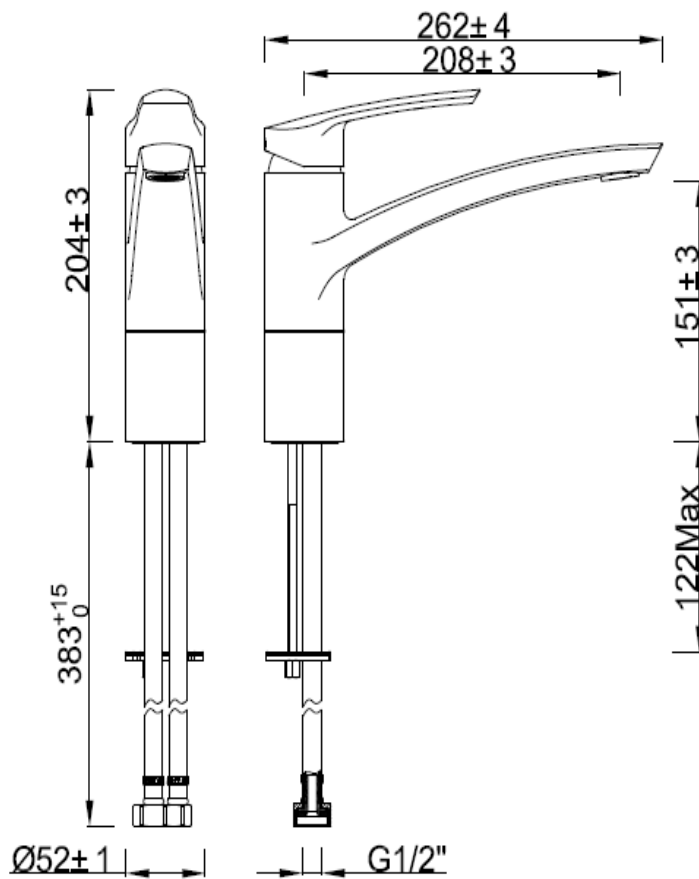

Technical Diagram



Exploded Diagram

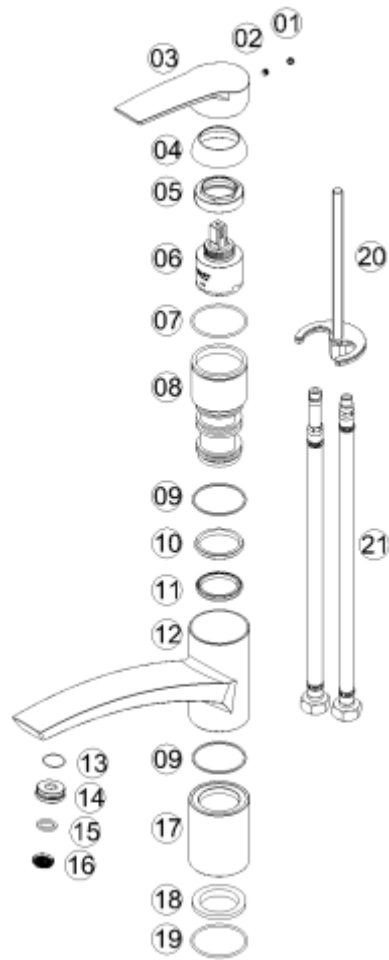

Item Number	Suppliers Identification code	Item Description	Qty	Price (If purchased as a spare part)
1	P71	Indice	1	Yes
2	SC5-4SN	Screw	1	Yes
3	177004-H	Handle	1	Yes
4	177004-S	Valve Cover	1	Yes
5	177033-N1	Cartridge Clamp	1	Yes
6	40D-1	Cartridge Assembly	1	Yes
7	OR152	O Ring	1	No
8	107005-N1	Valve Seat	1	No
9	M4102-02-01	Washer	2	No
10	M4102-02-02	Washer	1	No
11	OR035	Y Type Sealing Ring	1	No
12	177004-01	Tap Body	1	No
13	OR055	O ring	1	Yes
14	177004-N2	Adaptor	1	Yes
15	102301-N	Washer	1	Yes
16	01.5501.0.0001	Aerator	1	Yes
17	177004-N1	Adaptor	1	No
18	177004-N3	Adaptor	1	No
19	OR050	O ring	1	No
20	N247-B	Fixing kit	1	Yes
21	BZG10-1/2"-450-01	Braided Connectors	1	Yes

Flow Rates

Pressure (bar)	Flow rate matrix		
	Hot	Cold	Mixer
	With aerator		
0.1	2.25	2.86	4.39
0.2	4.50	4.34	6.09
0.3	5.46	5.24	7.43
0.4	6.36	6.30	8.58
0.5	7.20	7.08	9.54
1.0	10.20	10.08	13.92
1.5	12.36	12.36	17.16
2.0	14.52	14.40	20.04
3.0	17.58	17.73	23.01
4.0	21.24	20.58	28.08
5.0	23.04	22.98	30.60

FAQ

What should I do if my tap is dripping/leaking?

Cleaning the valve (if water dripping from tap)

Before carrying out any maintenance, turn off the mains water supply. If unsure contact a qualified tradesman.

1. Remove the cap(a) from the handle(c), loosen the grub screw(b).
2. Remove the handle(c), cover(d).
3. Remove the retaining nut(e) using a suitable spanner, remove the cartridge and clean
4. the cartridge(f) thoroughly under cold water to remove any build up of limescale or debris.
5. If necessary replace the cartridge(f).
6. Replace the cartridge(f) into the body, tighten the retaining nut(e) using a suitable spanner.
7. Replace the cover(d) and handle(c), tighten the grub screw(b) and re-fit cap(a) to handle.

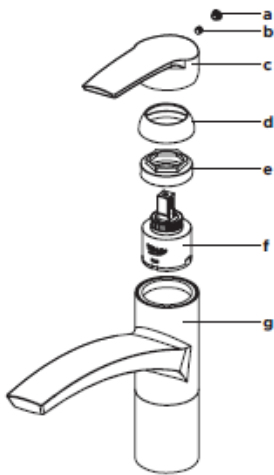

What does the Guarantee Cover?

The Guarantee Covering leakage, manufacturing defects and Chrome plating

The guarantee does not cover:

- Damage or defects caused by:
 - general wear and tear (including special non-chrome finishes; components such as filters, seals, 'O'rings and washers)
 - incorrect installation
 - repair using non- PPI parts
 - accidental or wilful misuse
 - corrosion and the use of inappropriate cleaning products.
 - system debris including the build up of limescale (which can be controlled through regular servicing and maintenance).
- Compensation for loss of use of the product or consequential loss of any kind.