

TECHNICAL DATA SHEET



Product Code: 295385

Product Description: iflo Astria Basin Mixer Tap (No Waste)



Product Specification

Material:
Solid brass with a duraglead chrome finish

Fittings:
Brass back nuts
Flexi Tails

Systems:
Suitable for high and low pressure systems
Suitable for Gravity fed systems
Suitable for Unvented systems
Suitable for Combi boilers

Additional Information

- Always inspect before installation
- Do not clean with abrasive cleaning products
- WRAS approved
- Eco click cartridge to aid water saving
- Lever style handles for ease of use

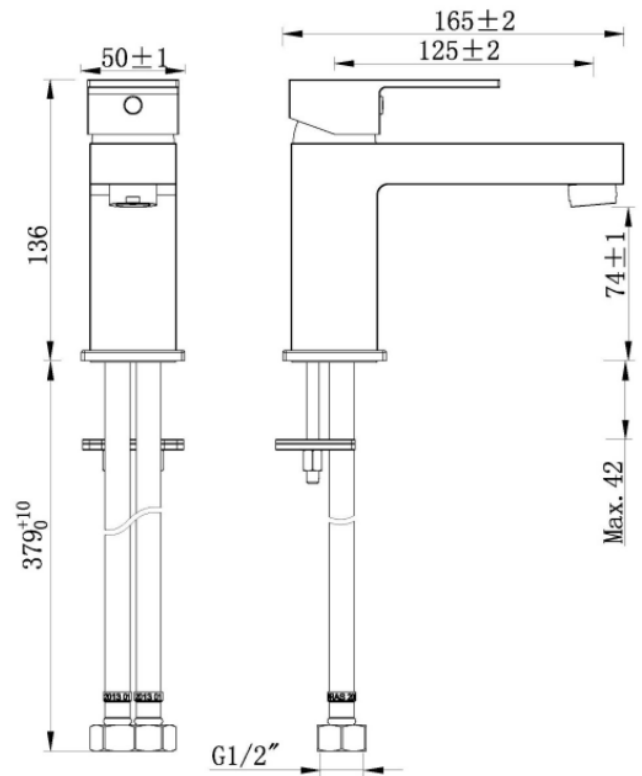

Pressure (bar)	Flow rate (l/m)					
	Hot		Cold		Mixer	
	Eco	Full open	Eco	Full open	Eco	Full open
0.1	1.40	2.84	1.44	2.50	1.21	2.84
0.2	1.94	3.86	2.08	3.70	1.72	3.96
0.3	2.38	4.56	2.48	4.52	2.12	4.88
0.4	2.74	5.26	3.00	5.32	2.40	5.56
0.5	3.08	5.84	3.38	6.00	2.72	6.32
1.0	4.50	8.06	4.56	8.40	4.20	9.20
1.5	5.66	10.02	5.69	10.40	5.26	11.22
2.0	6.22	11.80	6.64	12.04	6.30	13.26
3.0	7.70	14.50	7.82	14.88	7.30	16.20
4.0	8.72	16.66	8.84	17.20	8.36	18.96
5.0	9.50	18.80	9.90	19.30	9.28	21.30



The information contained herein is for guidance only and does not necessarily represent the products available. Travis Perkins PLC reserves the right to change product details and price without prior notice. E&OE' [10/2017]