

Product Code: 709157

Product Description: TRV 15MM X1/2 ANGLED TRV+LOCKSHIELD PACK

Product Specification

Material: Brass chrome plated

Size: 15mm

Technical Information:

Compliant to BS EN 215

Keymark approved



Manufacture date: MM/YY

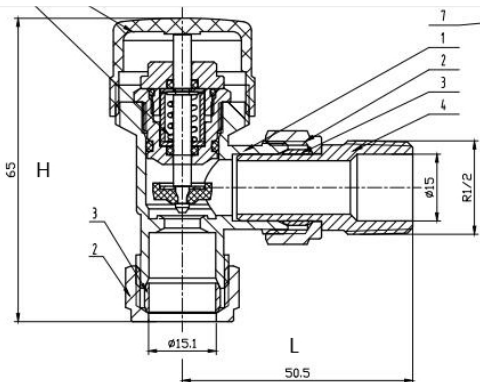

Size	DN	L	H	Kgs
15mm	15	50.5	65	0.338

Technical Data

Normal flow rate	176kgs/h
Max pressure difference	0.8Bar
Max flow temperature	120°C
Temperature Range	6°C to 28°C
Field of applications	cold and hot Water
Chrome finish	
Directional flow	- vertical or horizontal mounting

NO.	Part Name	Material	Qty
1	TRV Head	ABS	1
2	Angled Valve body	Brass	1
3	Connection Pie	Brass	2
4	Olive	Copper	4
5	Nut	Brass	4
6	Lockshield Valve body	Brass	1
7	Protective head	PP	1
8	Lockshield Protective head	PP	1

Guarantee Period:

5 Years against Manufacturing Defects