

# TECHNICAL DATA SHEET



Product Code: 295669

Product Description: iflo Waterscade Basin Mixer Tap (No Waste)

## Product Specification

Material:  
Solid brass with a duraglam chrome finish

Fittings:  
Metal & Rubber C Plate  
Bolt and nut  
Flexi Inlet Tails

Systems:  
Suitable for high and low pressure systems  
Suitable for Gravity fed systems  
Suitable for Unvented systems  
Suitable for Combi boilers

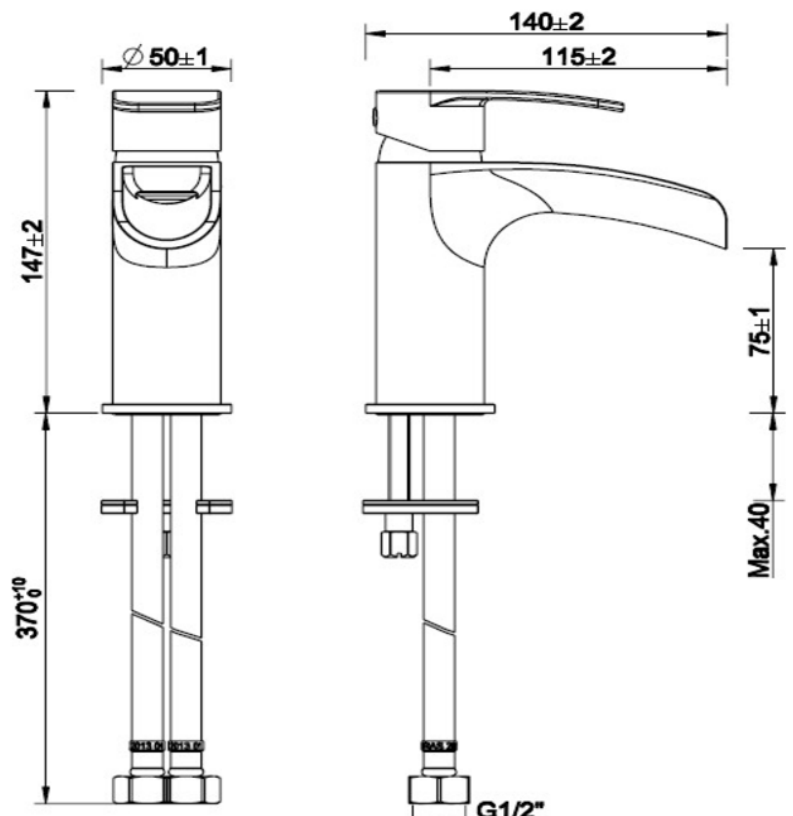

## Additional Information

Always inspect before installation

Do not clean with abrasive cleaning products

WRAS approved

Eco click to aid water

Lever style for ease of use

| Pressure (bar) | Flow rate (l/m) |           |       |           |       |           |
|----------------|-----------------|-----------|-------|-----------|-------|-----------|
|                | Hot             |           | Cold  |           | Mixer |           |
|                | Eco             | Full open | Eco   | Full open | Eco   | Full open |
| 0.1            | 1.44            | 2.48      | 1.44  | 2.32      | 1.38  | 2.88      |
| 0.2            | 2.04            | 3.72      | 2.10  | 3.60      | 1.92  | 4.12      |
| 0.3            | 2.44            | 4.48      | 2.56  | 4.48      | 2.28  | 5.00      |
| 0.4            | 2.82            | 5.24      | 3.06  | 5.24      | 2.64  | 5.80      |
| 0.5            | 3.06            | 5.84      | 3.32  | 6.00      | 2.94  | 6.64      |
| 1.0            | 4.32            | 8.12      | 4.80  | 8.56      | 4.20  | 9.20      |
| 1.5            | 5.46            | 9.92      | 6.00  | 10.56     | 5.28  | 11.48     |
| 2.0            | 6.12            | 11.16     | 6.69  | 12.28     | 6.12  | 13.28     |
| 3.0            | 7.32            | 14.34     | 8.58  | 15.30     | 7.62  | 16.62     |
| 4.0            | 8.34            | 16.68     | 9.66  | 17.40     | 8.46  | 18.90     |
| 5.0            | 9.00            | 18.18     | 10.74 | 19.50     | 9.56  | 21.48     |

cartridge saving

handles

'The information contained within this specification sheet is believed to be correct and complete at the time of creation. All photographs / drawings are as a guide only and do not necessarily represent the products available. Travis Perkins PLC reserves the right to change product details and price without prior notice. E&OE.' [10/2017]