



## Light Commercial Circulation Pump

## LCCP 25-80/180

### Overview

The Strada Products LCCP 25-80/180 circulation pump has been designed for installation on domestic and light commercial applications.

The LCCP is a natural choice for heating systems, which comes fitted with a powerful efficient motor along with an automatic speed controller, capable of automatically adjusting the pump performance.

### Features & Benefits

- Fully ErP compliant
- EEI rating of  $\leq 0.23$
- Automatic speed controller
- Powerful, quiet, efficient 70w motor
- Reliable and maintenance free
- Easy installation
- Maximum flow rate of 4 m<sup>3</sup>/h
- Maximum head rating of 8 meters
- Suitable for domestic and commercial applications
- 5 years warranty\*

\* 2 years standard warranty. 5 years warranty available with registration.

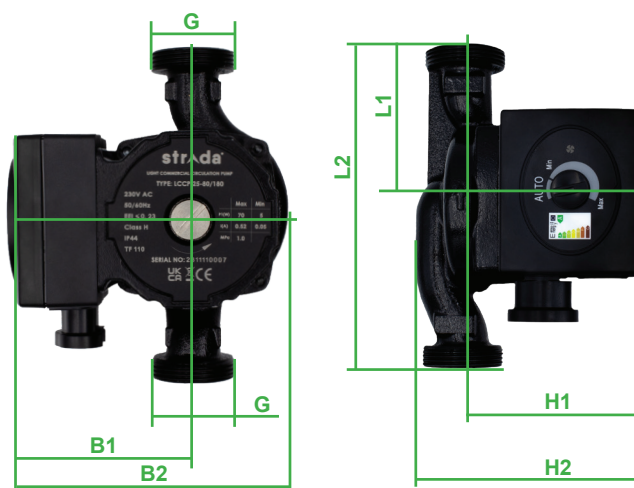

Specification	
Energy Efficiency Index (EEI Rating)	$\leq 0.23$
Power Rating (P1)	5w - 70w
Current (Amp)	0.05 - 0.52
Maximum System Pressure (mPa)	1.0 mpa
Temperature Class	TF 110
Degree of Protection	IP44
Insulation Class	Class H
Frequency (Hz)	60 Hz
Voltage (V)	230v ac

Dimensions			
L1	90	H1	103
L2	180	H2	130
B1	82	G	1 1/2"
B2	130		